



DISTRIBUTION STATEMENT A. Approved for public release, distribution is unlimited.

CERDEC C4ISR/EW Hardware/Software Convergence

14 SEP 16

Jason Dirner
Intel Technology and Architecture Branch
CERDEC I2WD



Problem Statement – Why Converge?



***Years of quick reaction solutions
have resulted in unsustainable
SWaP-C and operator overload***

Current generation of C4ISR/EW systems exceed the size, weight, and/or power available on current and planned future platforms

At the core, C4ISR/EW systems use many of the same building blocks, but they are not shared or distributed between systems (e.g., amplifiers, filters, processors)

Each additional capability or function comes as its own “system” resulting in:

- Integration challenges
 - Competition for limited platform resources
 - Redundant sub-system components
 - Complex, costly and weighty cabling
 - Excessive heat generation
 - Less space on the platform for soldiers
- RF compatibility concerns
- High cost of maintaining and upgrading

Platforms – not just soldiers – are overburdened



HW/SW Convergence Initiative

- Defined a converged architecture that provides open interfaces to enable rapid insertion of new capabilities, interoperability and a reduced SWaP footprint
 - Enable sharing of hardware and software among C4ISR/EW capabilities
 - Allow technology refresh to keep pace with threats and improve robustness
 - Permit innovative but unplanned capabilities to be rapidly implemented
 - Reduce developmental and acquisition costs through greater competition
- Established a Working-level Integrated Product Team (WIPT) to coordinate development activities and yearly demonstrations
 - Many organizations internal and external to CERDEC are participating including Government, Industry and Academia
 - Organizations leveraging their tech base to develop capabilities against the standards
 - Verifies technical validity of the multifunction architecture
 - Matures the specifications and identifies gaps that can be corrected early
 - Buys down risk for future implementations





Layered Standards

- Layered approach to an architecture: Standards and specifications are individually useful, and can be combined to form a holistic converged architecture
- The aggregate architecture and associated standards is referred to as the **C4ISR/EW Modular Open Suite of Standards (CMOSS)**

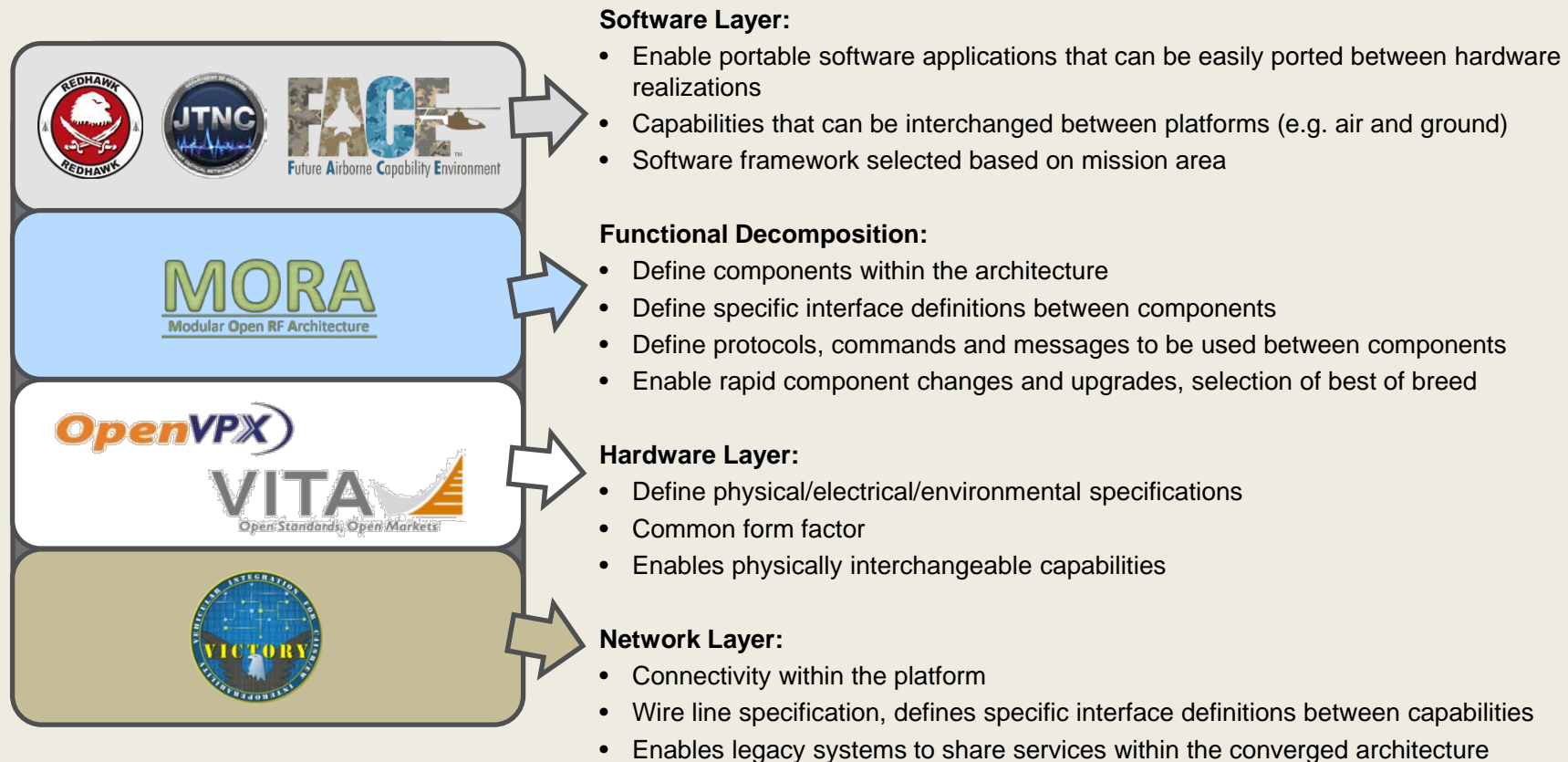



Traditional Approach



“Bolt On” Mission Equipment Integration

VICTORY Approach



VICTORY Data Bus enables interoperability across C4ISR/EW and platform systems

Adds a network data bus to vehicles

- Specifies “on-the-wire” network-based interfaces for discovery, management, health publishing, and data exchange
- Provides shared hardware and user interface hardware
- Provides shared services including time synchronization, position, orientation, and direction of travel
- Supports IA requirements and “defense in depth” security designs

Benefits both platform and mission equipment design and implementation

- Reduces SWaP-C impact of GFE over time
- Enables new capabilities through interoperability over a vehicle network – the VICTORY Data Bus (VDB)
- Enables commonality of specifications, software and hardware
- Reduces overall life cycle costs through competition
- Maximizes C4ISR/EW portability

ASA(ALT) is requiring PEOs/PMs to include VICTORY in their acquisition strategy

VICTORY enables interoperability across C4ISR, EW, and platform systems on Army ground vehicles. Technical approach is applicable to air, sea, and subsurface platforms.

Modular Open RF Architecture

VICTORY Data Bus (VDB)

Provides a network data bus to integrate C4ISR/EW system. Includes:

- Standard interfaces for discovery, monitoring, and management.
- Shared HW resources.
- Shared data services.
- Shared IA services.

MORA Low Latency Bus (ML2B)

Addressable bus for real-time communication.

- Replaces discrete signals to improve interoperability and scalability.
- Supports real-time control and digital RF using VITA 49.2.

RF Bus

RF can be transmitted as analog over coax, RF over fiber, or digital RF over ML2B.

Shared Process Unit

Enables computing from multiple applications to be hosted on common hardware.

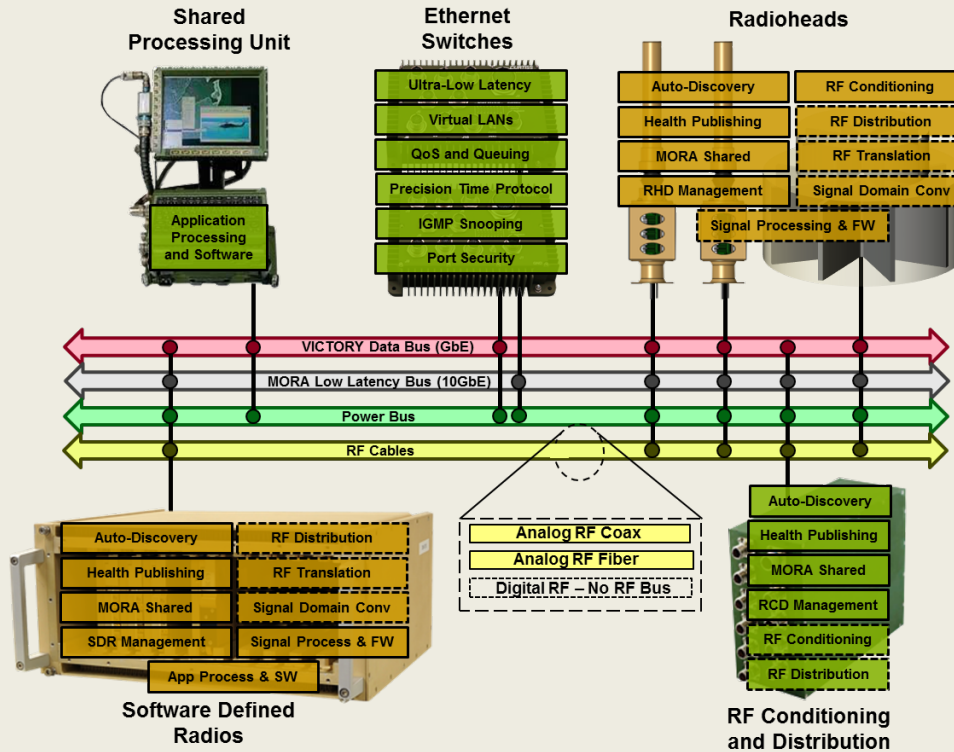

MORA decomposes RF capabilities into high-level functions with well-defined interfaces.

- Reduces SWaP by enabling hardware sharing.
- Establishes pooled, flexible resources that can be configured based on mission needs.
- Enables rapid technology insertion to address emerging requirements or threats.
- Improves system efficiency and survivability.

SDR

Combination of analog and digital signal processing.

- Waveforms are implemented in software on a GPP, DSP, or FPGA.
- Enables rapid reprovisioning of RF HW based on mission needs.

Radiohead

Remote PA integrated with the antenna.

- Enables low power RF within the platform which reduces heat load and signal loss through cables.
- Immediate amplification of received signals reduces noise and improves overall system performance.

RFDD

RF switch to route RF signals between components.

- Allows sharing and remote location of amplifiers.
- Enables hardware failover to improve system survivability.
- Facilitates 3rd party technology insertion.

Backplane Profile

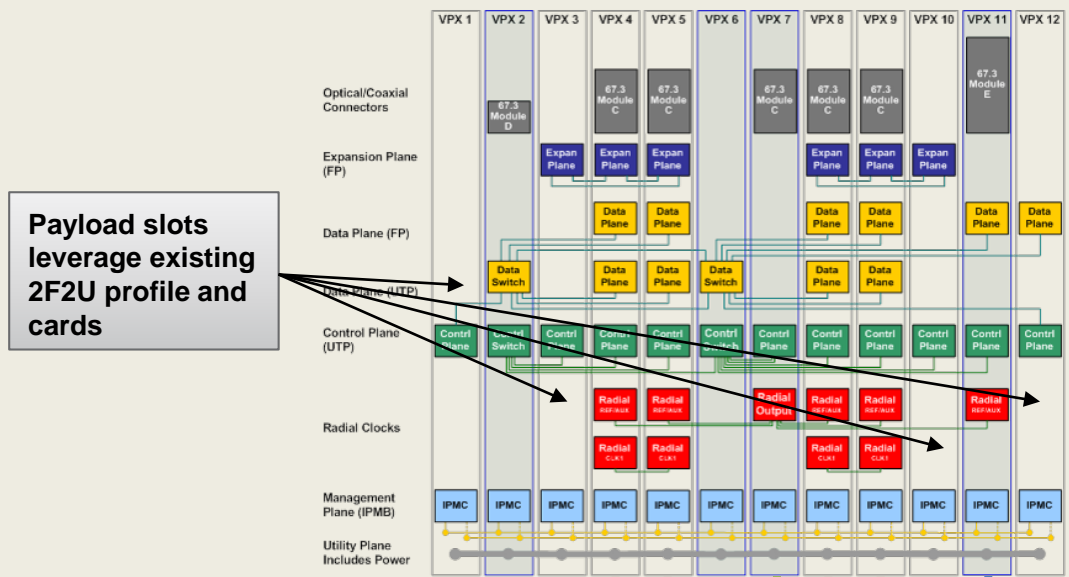

- Supports DoD-specific concerns including:**
- Radial clock distribution for phase coherent operation
 - Blind-mate optical and coaxial connectors for two-level maintenance
- Maximizes interoperability by:**
- Specifying a single slot profile for each type of card
 - Limiting protocols to a single technology family
 - Limiting the use of user-defined pins

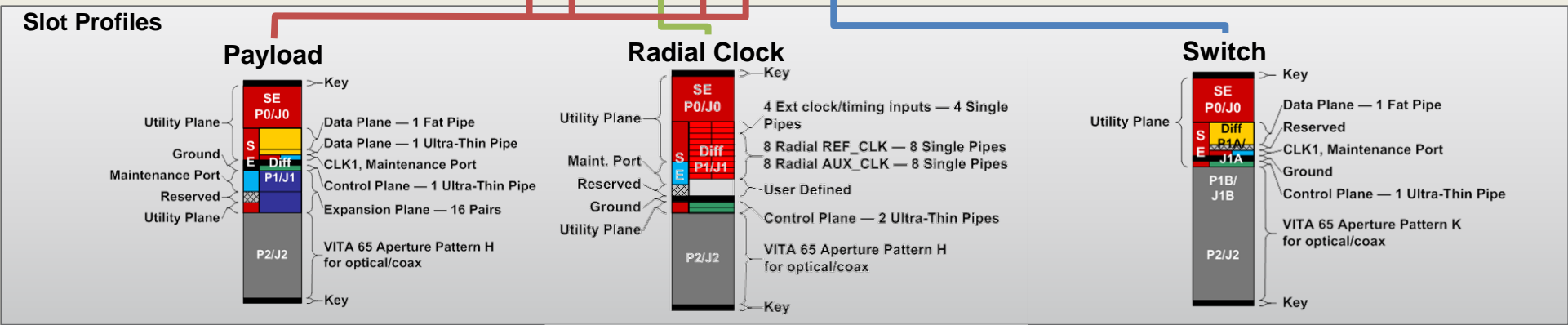

Common backplane profiles enable capability reuse and shared investment across programs and services

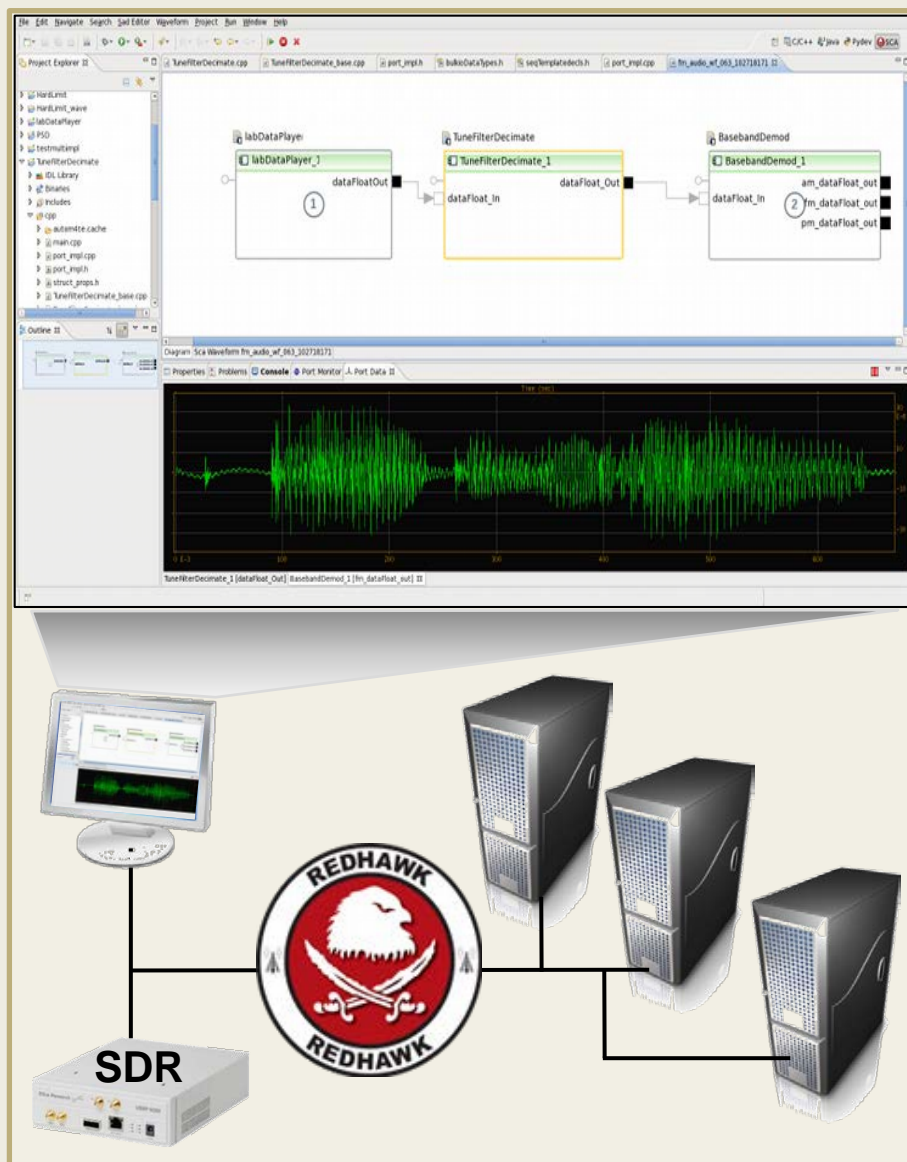

Purpose:

REDHAWK is a JTRS SCA based Free and Open Source Software (FOSS) framework intended to facilitate the development, deployment, and management of Software Defined Radio (SDR) applications. SDR applications are developed by linking modular software components into a Waveform. I/O streams and control between the Waveform and SDRs are defined by standard interfaces and dependencies, decoupling Waveform development from hardware considerations. The Waveform can then be deployed to local or networked REDHAWK enabled hardware that supports its dependencies to be executed and managed.

Products:

- Eclipse based IDE for development of SDR components and applications in C++, Java, or Python.
- Framework services allowing networked application deployment and execution.
- Interface for life-cycle management of running SDR applications through the IDE, a Python terminal, or user GUI.
- Community supported library of reusable software components.

Payoff:

- Reduced time to develop and field SDR applications.
- Networked SDR application deployment allowing pooled resources to mitigate hardware failure.
- Real-time management of executing SDR applications.
- Hardware agnostic SDR applications reducing SWAP-C impact on platforms through hardware reuse.
- A standard interface to SDRs for application / algorithm designers.
- A library of SDR and signal processing blocks.
- A method of networking and managing available resources and applications.



Architecture Overview

Radioheads (Antenna + PA)

C4ISR/EW Sensors

Software Defined Radios

OpenVPX Chassis

RF Distribution Device

VICTORY Shared Processing Unit

SPU APIs:

- Runtime Environments
- Native Libraries

C4ISR/EW Applications:

- C2/SA
- Health Monitoring
- Automation

REDHAWK Framework:

- IDE / GUI
- CORBA Server
- Domain Manager
- Device Manager
- GPP Device Driver

FACE:

- Portable Components
- Transport Services
- Platform Specific Services
- I/O Services

REDHAWK C2/Monitoring



VICTORY Data Bus

MORA Low Latency Bus

Power Bus

RF Bus

SDR 1

REDHAWK Framework

- CORBA Client
- Device Manager
- GPP Device Driver
- SDR Device Driver

EW Application

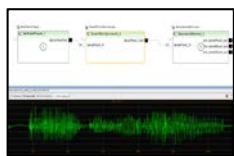

SDR 2

Software Communications Architecture (SCA) OE

- Core Framework Control
- Platform Devices and Services

Comms Application

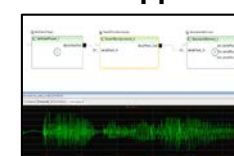



Architecture Overview

VICTORY Shared Processing Unit

SPU APIs:

- Runtime Environments
- Native Libraries

C4ISR/EW Applications:

- C2/SA
- Health Monitoring
- Automation

REDHAWK Framework:

- IDE / GUI
- CORBA Server
- Domain Manager
- Device Manager
- GPP Device Driver

FACE:

- Portable Components
- Transport Services
- Platform Specific Services
- I/O Services

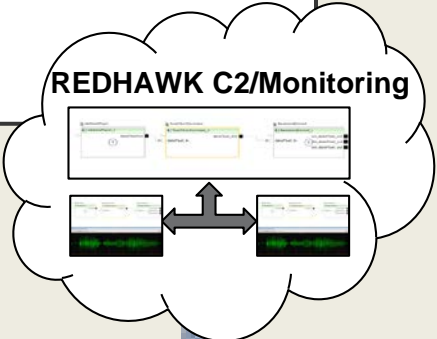
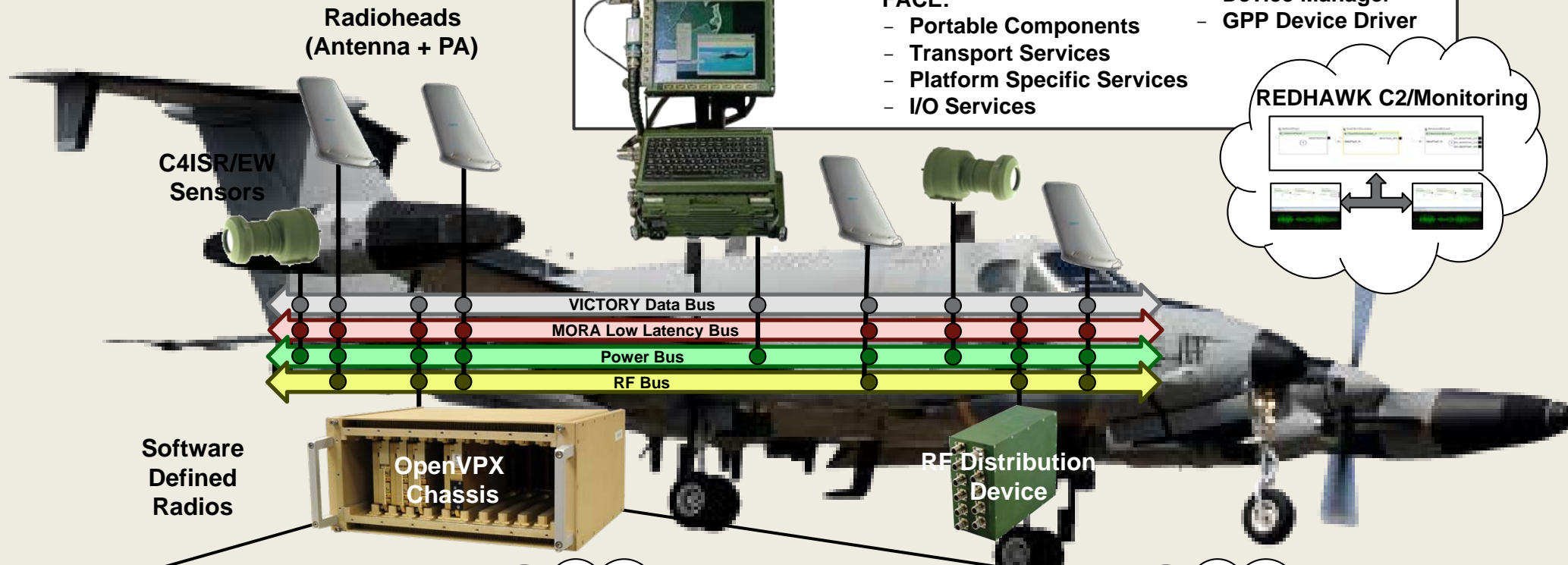

SDR 1

REDHAWK Framework

- CORBA Client
- Device Manager
- GPP Device Driver
- SDR Device Driver

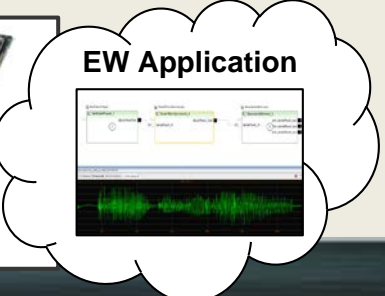

SDR 2

Software Communications Architecture (SCA) OE

- Core Framework Control
- Platform Devices and Services



Phase 1 (FY14-15) – Proof of Concept

- Improve SWaP via a common chassis for C4ISR/EW
- Define an architecture at the hardware, software, and network layers
- Validate the architecture by integrating EW, Comms, PNT, and Sensors
- Develop standards for RF distribution
- Select a low latency bus for real-time coordination
- Research and select a backplane with a common chassis
- Investigate IA and EMI concerns with a common chassis
- Lab demo in April 2015

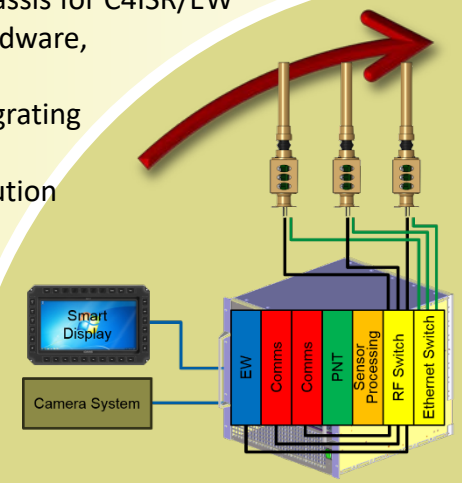

Phase 2 (FY15-17) – Tactical Implementation

- Define backplane to minimize external wires and enable precise time synchronization
- Integrate EW, Comms, PNT, and Sensor processing in a ruggedized chassis
- Implement and demonstrate a low latency bus for real-time control
- Integrate required IA controls
- Develop higher fidelity standards for RF distribution, conditioning, translation, and signal domain conversion
- Lab demo in FY16, vehicle demo in FY17

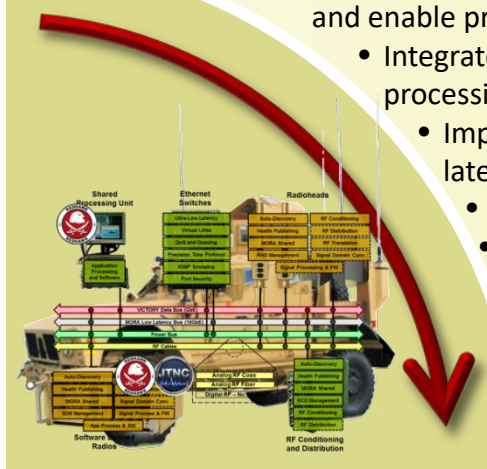

Phase 3 (FY17+) – Future S&T

- Leverage open interfaces to demonstrate compatibility, interoperability and resource sharing
- Implement digital RF to facilitate RF distribution
- Integrate additional capabilities in architecture
- Port additional waveforms
- Shared amplifiers and antennas
- Real-time coordination between capabilities
- SDR frameworks and support for HW acceleration

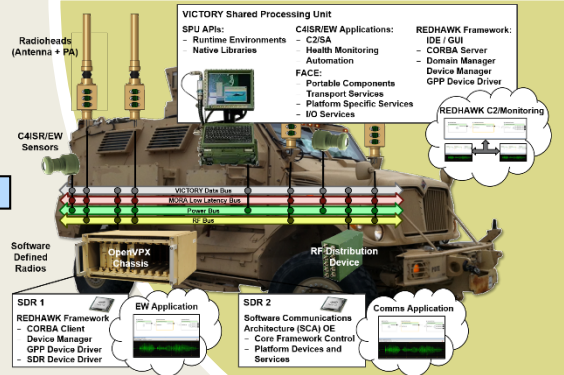

Develop and mature specifications for a converged architecture during the FY14-17 timeframe. Transition resulting standards to the acquisition community for inclusion in future solicitations and requirements.



DoD OpenVPX Profiles

- Custom backplane built in accordance with the backplane and slot profiles defined by HW/SW Convergence
- Includes extensions for radial clocks and blind-mate coaxial/optical connectors
- Ruggedized chassis to support a limited vehicle demo

Comms Implementation

- Comms capability implemented within the chassis on OpenVPX cards

EW Implementation

- Multiple EW capabilities implemented within the chassis on OpenVPX cards

RF Switch

- RF switch implemented within the chassis on OpenVPX card
- Directs EW and Comms signals to appropriate Radioheads

PNT Implementation

- GPS receiver integrated within the chassis on OpenVPX card
- Provides platform position and time reference
- Radial clocks enable phase coherent operation across cards in the chassis

Mission Command Implementation

- Mission Command application running on smart display

Sensor Implementation

- Video sensor provides “look-ahead” on smart display
- Video processing on COTS SBC within the chassis

Radiohead

- Antenna with wideband amplifier used for all RF missions
- Controlled by real-time messages over the ML2B

MORA Interfaces

- Used for monitoring and management of RF capabilities
- MORA HMI on smart display provides control for EW/Comms cards, Radioheads, and RF switching

VICTORY Interfaces

- Shared data services for time and position
- IA services for authentication and access control
- Interfaces for streaming video and camera control

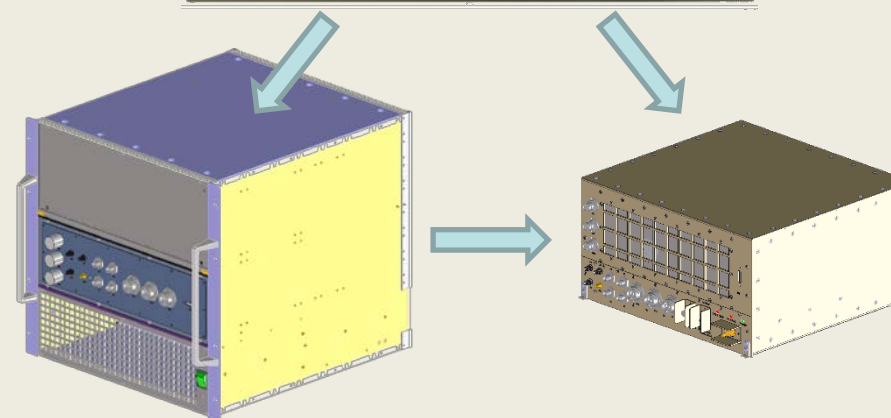
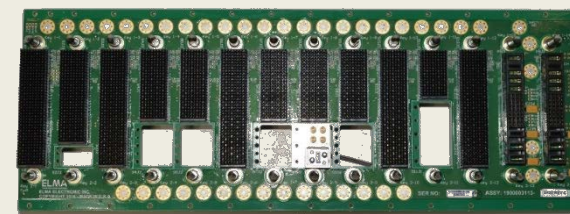



U.S. ARMY
RDECOM

Publications



Adam Melber, Jason Dirner, "Modular Open RF Architecture: Extending VICTORY to RF Systems," *2015 NDIA Ground Vehicle Systems Engineering and Technology Symposium (GVSETS)*, August 2015.



Mohamed Khalil, Michael Williams, Christine Connelly, Daniel Sharpe, Benjamin Peddicord, "3U OpenVPX Radio Card Module Development for Hardware/Software Convergence Program," *2015 NDIA Ground Vehicle Systems Engineering and Technology Symposium (GVSETS)*, August 2015.



Adam Melber, Jason Dirner, "Modular Open RF Architecture: Extending VICTORY to RF Systems," *SPIE Open Architecture / Open Business Model Net-Centric Systems and Defense Transformation 2015, vol 9479*, April 2015.



Benjamin Peddicord, Jason Dirner, "C4ISR/EW Interoperability Framework," *Embedded Tech Trends*, January 2015.



Jason Dirner, Adam Melber, John A Pankowski, "Why Some Standards Don't Guarantee Interoperability," *2014 NDIA Ground Vehicle Systems Engineering and Technology Symposium (GVSETS)*, August 2014.



Paul Zablocky, Seth Spoenlein, Benjamin Peddicord, Yevgeny Ivanyutin, Ryan Nilsen, Paul Sass, David Waring, "Hardware/Software Convergence for C4ISR/EW," *MILCOM 2014*, October 2014.